

# The Wing & Bonnet

September Issue - 2023

Vol. 30, No 9

The Official Newsletter of The British Car Club of Wichita

[www.britishcarclubofwichita.com](http://www.britishcarclubofwichita.com)



## Hello Everyone!

This is coming to you from **Istanbul Turkey**. The summer is almost over which is a good thing because it has been too hot to drive the cars. Hopefully it will cool down in September. We are planning on having the **Annual BCCW Picnic** at Sharon's house in Yoder, Kansas, this year. Please Call Sharon or Lew for count of attendees. **PICNIC DETAILS ARE IN BOX TO THE RIGHT**>

Hope everybody has a safe month and we get to drive the cars.

### **Dan and Shirley**

Daniel P. Johnson, PhD  
Creative Presentations  
[DJsKreativ@aol.com](mailto:DJsKreativ@aol.com)  
316-641-1589

### **BCCW Hats/T-Shirts - \$5 CLEARANCE**

White BCCW T-Shirt Small - 1 LEFT  
White BCCW T-Shirt Med - 4 LEFT  
Tan BCCW T-Shirt XLG - 2 LEFT  
ONLY 2 HATS LEFT \$5 EA  
PATCHES \$1.00 (SEE PAGE 10)

**SHARON BRILLHART 620-200-4959**

### **The Wing & Bonnet**

**President** [DJsKreativ@aol.com](mailto:DJsKreativ@aol.com) Dan Johnson(316) 641-1589

**Treasurer** **Checks made out to BCCW and mailed to)**  
**Tammy Vandruff 700 S Madison** [Kenvandruff@aol.com](mailto:Kenvandruff@aol.com)  
Wichita KS 67211 (316) 265-9954

#### **Technical Advisors**

Joe Henning (316) 524-4128  
Tom Piacenza (316) 778-1549  
Hank Brillhart (316) 204-2596

#### **Newsletter Editor**

**Lewis Blackwell** 929 East 52 South, Wichita, KS 67216  
(316) 990-2533 [lewblac78@gmail.com](mailto:lewblac78@gmail.com)

#### **Web Site Team**

Hank Brillhart [hankb72@cox.net](mailto:hankb72@cox.net)  
Jeff Cowell, Web Master [jeff@douglasphoto.com](mailto:jeff@douglasphoto.com)

### **BCCW ANNUAL FAMILY PICNIC**

**Sept 23 From 11am to 4pm Sharon's farm 402 West Red Rock Rd, YODER**

**YOU** bring chairs, **side dish** to share; CLUB will supply all else: meats, pop, **burgers/brats/dogs**. Desert will be whatever appears.

**Directions:** Drive NW on K-96, Exit to Yoder, go to Bulls Eye Burger, go (?) miles west to the white farm, 402 W. Red Rock with orange cone on driveway. **Call 620-200-4959 if lost.**

**Entertainment:** Cone Complex, Corn Hole Game, Kids View Horses across road with adult.

**Backyard Target** firing range will be available for exercising your personal equipment that you may bring. Safety encouraged.

**CALL SHARON 620-200-4959**

**ONLY IF COMNG. (OR Lew 990-2533)**

**Leave message NAME, NUMBER in party**

# IN THE REAR VIEW MIRROR



The August Cars and Coffee Show had a better turnout with better weather than in July. **BCCW British & Other Cars** were well represented. Paul Briggs brought his new toy, a red Jaguar and Roger Pitts brought his MGB. It was a good turnout of club cars photos of which your editor missed due to my late arrival. My apologies! A sampling is shown below:

A large part of the entertainment portion of the Cars and Coffee was the crowds that gathered at the entry / exit, where onlookers got to see and HEAR burnouts and raceaways of the various high-octane, high-speed vehicles, at upper right >

Cars and Coffee runs March to October, so you still have time to join in MAYBE cooler weather?





Amazing what you find driving around.

Diagonally South & East, opposite the campus location of the Cars and Coffee venue, is an impressive impression of a turtle in an aesthetically innovative avant garde art form. This piece incorporates its own security system of cameras!

There is no worry that this art will be in danger of blowing away in a storm.

## CARS & PARTS OF CARS FOR SALE / MAYBE FREE

Gearbox cover, fiberglass. \$45. Came with some parts cars I bought long ago. Looks like it has been installed once and promptly pulled. One mounting tab needs repaired, otherwise in very good condition.

**Fits TR4,4a,250 & 6.** New phenolic unit from The Roadster Factory is \$110 + shipping. Pick up is best, as shipping will be a killer on something this big. Will ship, but don't recommend it. 31six 77six 00six5. **Other TR3 & 4 parts available, inquire.**

**HARRY PRICE**

xk150fhc@sbcglobal.net



**FROM STEVE OLSON ~  
DUCT TAPE or ZIP TIES**

British cars should carry an ample supply of both. On our trip to Calgary (MG Annual Show), I used zip ties to reattach electric fan to radiator. Also used duct tape for split in armrest pad.

At the event, John Twist used duct tape to fix an intake manifold leak. Concourse points are worthless when your car won't run.



**72 MG MIDGET BODY!**

*Tony Lane Has A Deal For You!*

Call Tony at **316-650-2394** or email [AnthonyL@sipptech.com](mailto:AnthonyL@sipptech.com)

..... I have a **72 MG Midget Body** with **all the body panels** if someone is looking for a parts car.

This is the car that I robbed the rear I would like to get rid of this body, and would deliver it to someone if they would like to have it for parts and references. Let me know.

Call Tony at **316-650-2394**

**ALL SAT NITES at BRAUM'S**



6 PM Liar's Club gathers outside in the parking lot with chairs or inside when it rains. All welcome.



# MOTOR OIL NOTES

You need to know where your next can of 20W50 oil is coming from. *Do you?*



*From Steve Olson*

Just when I thought I had found a perfect oil for my British cars, **WalMart** decided to no longer carry **Castrol GTX Classic 20W50**. And they had been the exclusive marketer for it. **Castrol** informed me **AutoZone** was now the exclusive seller.

So today I went to the **AutoZone** near me. Employees there could barely spell OIL. None was on display and if they had any behind the counter they didn't know about it. I didn't have an immediate need

so I came home and checked eBay. I now have a 5 qt jug on its way for only **\$25.99** plus tax and with free shipping. Pretty sure it would have been significantly more from AutoZone. Finding a good high zinc oil is more difficult than necessary.

## **Additional note: 20 W 50 Oil**

Most places that sell **high zinc motor oil** like **VR1** don't have it out on display where customers could just pick it up. They might mistakenly use it in their modern cars, **shorten the life of their catalytic converters**, and then sue the store where they accidentally bought it. WalMart's lawyers probably were worried that their customers were just dumb enough to do that. Plus it likely wasn't just flying off their shelves with no advertising.

Maybe Moss will pick up the distribution contract. But then it would cost \$50 a jug plus shipping and handling.

I should probably stock up while eBay still has some.

*Steve Olson*

# THE ILLUSTRATED OVERDRIVE

LdN Overdrive: The British invention that let the world's drivers enjoy highways.

Andrew English 2023

## THE LAYCOCK DE NORMANVILLE OVERDRIVE UNIT

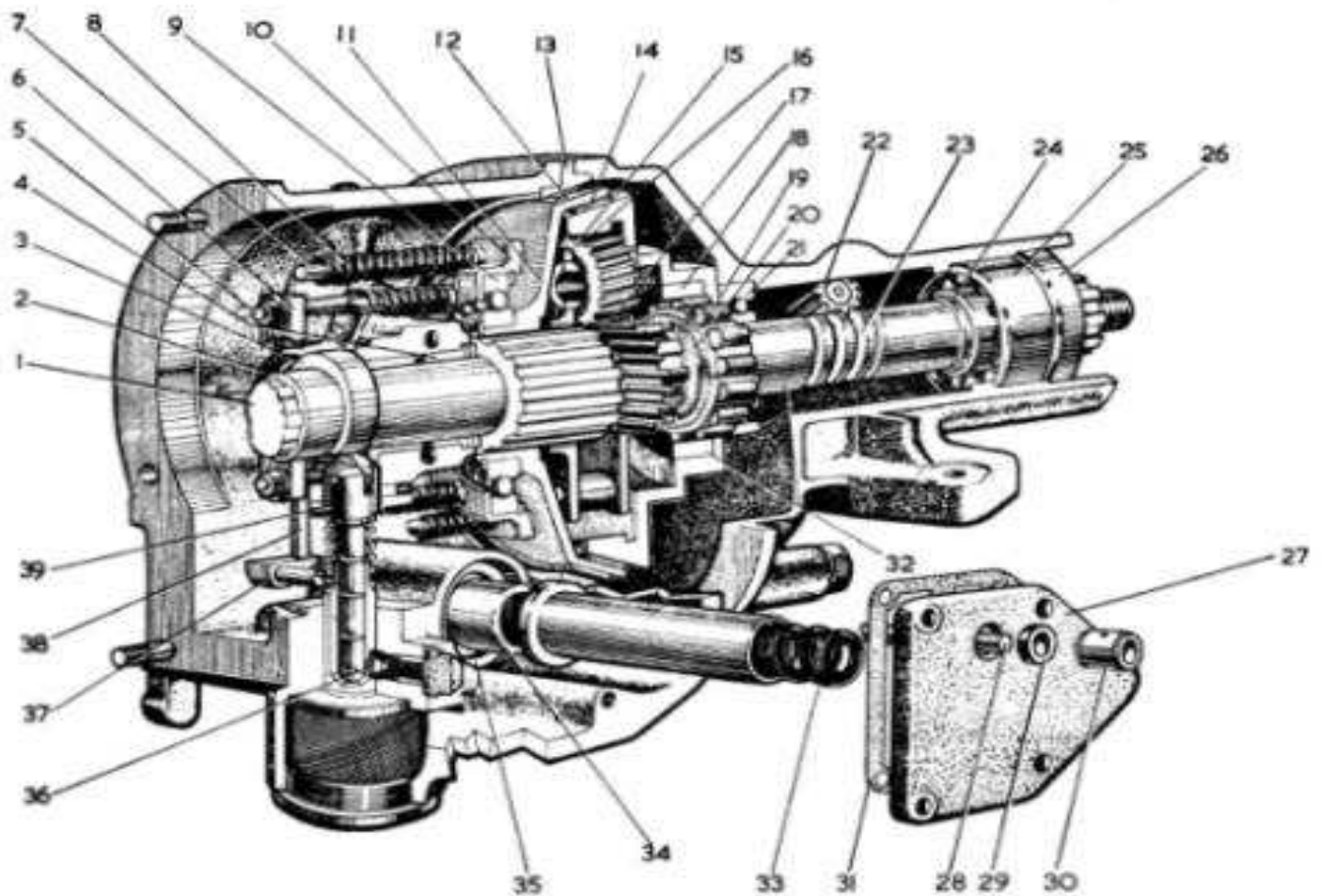

FOR FULL ARTICLE, GO TO: [https://www.hagerty.com/media/maintenance-and-tech/ldn-overdrive-the-british-invention-that-let-the-worlds-drivers-enjoy-highways/?utm\\_source=SFMC&utm\\_medium=email&utm\\_content=MED\\_UN\\_NA\\_EML\\_UN\\_WeekendRoadTrip&hashed\\_email=d99fb4ac6f070a2662d732938817d981d3658b05affc5e8cb758591e0b6805ea&dtm\\_em=d99fb4ac6f070a2662d732938817d981d3658b05affc5e8cb758591e0b6805ea](https://www.hagerty.com/media/maintenance-and-tech/ldn-overdrive-the-british-invention-that-let-the-worlds-drivers-enjoy-highways/?utm_source=SFMC&utm_medium=email&utm_content=MED_UN_NA_EML_UN_WeekendRoadTrip&hashed_email=d99fb4ac6f070a2662d732938817d981d3658b05affc5e8cb758591e0b6805ea&dtm_em=d99fb4ac6f070a2662d732938817d981d3658b05affc5e8cb758591e0b6805ea)

**Commentary on following page**

# Commentary on the Overdrive Lubrication

*From Steve Olson*

The guy that runs **Quantum Mechanics** where they rebuild many of our Overdrives says **gear oil is too thick** and can over-pressurize components. **20 W 50** has additives that may foam up. He insists straight **30 non-detergent is best**.

Detergent oils keep particles in suspension and keep them circulating. With no real filter to grab them we are better off letting them settle to the bottom. He also thinks tranny lube needs to be changed every couple years.

When I recently dropped the cover on my Overdrive, the screen and filter both had almost nothing trapped in them. The magnets had a coating of very fine metallic particles.

I did replace one O-ring on the pump piston that looked like it might have hardened. I have tried almost all lubricants except Extra Virgin Olive Oil and currently run **20 W 50**.

The **90-140 Gear Oil** did seem too thick to let the synchros work and the **ATF** seemed too thin to not leak out. **Red Line** and other "special" lubes are too pricey for me.

.....In the future I might try some straight 30 lawnmower oil.

*Overdrive Overview access to complete article:*

[https://www.hagerty.com/media/maintenance-and-tech/ldn-overdrive-the-british-invention-that-let-the-worlds-drivers-enjoy-high-ways/?utm\\_source=SFMC&utm\\_medium=email&utm\\_content=MED\\_UN\\_NA\\_EML\\_UN\\_WeekendRoadTrip&hashed\\_email=d99fb4ac6f070a2662d732938817d981d3658b05affc5e8cb758591e0b6805ea&dtm\\_em=d99fb4ac6f070a2662d732938817d981d3658b05affc5e8cb758591e0b6805ea](https://www.hagerty.com/media/maintenance-and-tech/ldn-overdrive-the-british-invention-that-let-the-worlds-drivers-enjoy-high-ways/?utm_source=SFMC&utm_medium=email&utm_content=MED_UN_NA_EML_UN_WeekendRoadTrip&hashed_email=d99fb4ac6f070a2662d732938817d981d3658b05affc5e8cb758591e0b6805ea&dtm_em=d99fb4ac6f070a2662d732938817d981d3658b05affc5e8cb758591e0b6805ea)

## UPCOMING CAR SHOWS & FESTIVALS

### National Car Show

17th Annual Brits in the **Ozarks**  
All British Car & Cycle Show,

**September 5 - 7 2023**

**SPECIAL GUEST KENT  
PRATHER, SCCA CHAMPION  
& STORYTELLER!**

Driving Tours 5th, Hotel Party Fri 6th,  
Show & Banquet Sat 7th

Register \$25 to get FREE T-Shirt

or \$35 Late Register and no shirt.



# MG Mitten and the art of selling accessories - by David LaChance

The image is a collage of vintage advertisements for MG Mitten and Marion Weber's Motoring Accessories & Racing Equipment. The top left ad features a red MG racing car and a driver wearing a red helmet and goggles, with a large red mitten graphic. The main headline reads "MG MITTEN" and the sub-headline says "MOTORING ACCESSORIES & RACING EQUIPMENT". Below this, there are several smaller ads for various products including "MG MITTEN CAR COVERS", "RACE & RALLYE" gear like goggles and helmets, and "GLOVE BOX" items. The ads include detailed descriptions of the products, their benefits, and prices. For example, the "MG MITTEN CAR COVERS" ad lists various models and their prices, while the "RACE & RALLYE" section lists items like goggles, helmets, and jackets. The "GLOVE BOX" section features various styles of driving gloves. The bottom right of the collage includes an "ORDER NOW" section with a form for customers to place orders, listing the company's address and phone number.

From [Hemmings.com/stories/mg-mitten-and-the-art-of-selling-accessories/](https://www.hemmings.com/stories/mg-mitten-and-the-art-of-selling-accessories/)

If there was anything that postwar American driving enthusiasts loved as much as their little British roadsters, it was dressing them up. Overnight, an entire cottage industry arose, catering to owners' needs to bedeck their sports cars with driving lamps, bumper overrides, sheepskin seat covers, and any number of other items to make them even more fun to live with—and to make them stand out in gatherings with fellow enthusiasts. Many of these sellers also offered all the gear needed to go racing, which back then wasn't much more than a helmet and some seatbelts.

MG Mitten was one of the pioneers in the field, and one of the most enduring, too, mailing out catalogs and parts from its Pasadena, California, warehouse from the early 1950s to the mid-1980s. Running the ship was founder Marion Weber, who greeted her customers with a breezy little commentary each month in the ads she ran in *Road & Track* and *Sports Cars Illustrated*, later *Car and Driver*.

The "Mitten" part of MG Mitten was a car cover, offered in a variety of fabrics for a range of sports cars. The cover was Weber's first product, launched in 1952 after a car cover she'd made for her husband's MG TC left his car club buddies clamoring for copies. The Mitten was followed by Healey Huggers, Porsche Parkas, Fiat Frocks, Jaguar Jackets, and other tailored covers with similarly alliterative names, all manufactured by a company called Covercraft International. She added to the catalog of gear from other suppliers, items like wooden shift knobs, driving gloves, sports jackets, steering wheel covers, SU adjusting tools, and much more.

For full article, go to <https://www.hemmings.com/stories/mg-mitten-and-the-art-of-selling-accessories/>

# SCCA RACING SCHEDULE



## SCCA RACE DATES September is Salina!

## Autocross Season

Sharon & Hank say if you would like to **SEE & FEEL** what this is like, come out to one of our autocrosses and **RIDE CREW IN THE PASSENGER SEAT!** You won't be disappointed with your experience.

Call Hank & Sharon Brillhart at 204-2596 and find new fast fun & friends! Or visit SCCA at, [www.wichitascca.org](http://www.wichitascca.org)!

## BCCW Hats/T-Shirts \$5 CLEARANCE

White BCCW T-Shirt Small - 1 LEFT  
White BCCW T-Shirt Med - 4 LEFT  
Tan BCCW T-Shirt XLG - 2 LEFT  
ONLY 2 HATS LEFT \$5 EA  
PATCHES \$1.00 WHILE THEY LAST

**CALL SHARON BRILLHART 620-200-4959**



North American MGB Register

The only MEMBER-RUN organization for MGB, MGC, Midget, 1100/1300 and Post Abingdon Car owners.

**ANNUAL MEMBERSHIP \$30** (\$45 overseas)

- Dash plaque • Membership card • Window decal
- Six bi-monthly issues of *The MG Driver*, a 68-page informative magazine.
- Annual national convention – a four-day MG party!

**North American MGB Register**

PO BOX 876 • Downers Grove, IL 60515-0876

Toll-free phone: 800-NAMGBR-1

[www.namgbr.org](http://www.namgbr.org)

## **HIGH SECURITY STORAGE**

Car storage now available. Conveniently located in west-central Wichita. Secure access. Reasonably priced. Car/Boat/Cycle/Small RVs Call **Bill Bruce 210-6365**  
[w-bruce@sbcglobal.net](mailto:w-bruce@sbcglobal.net)

## **Don't sit around on your ad if you want your new business to *FLY!***

**Ric Wolford** supports British Car Club of Wichita with Website & print!

Bring your graphic & photo needs to **Douglas**



**Photo Imaging!** Drop in and see **Ric** at 2300 East Douglas Wichita. Enter west door to view **ART** all the way up hallways to front counter. Great samples of excellent photography await! Call 316-264-3013 Connect: [ric@douglasphoto.com](mailto:ric@douglasphoto.com)

**Are all your vents & windows open with the heater running to cool your engine?** Maybe it's time for radiator check up? **B & R** has done good work for me. *Editor*



### **B & R Radiator, Inc.**

*"A Good Place To Take A Leak"*  
1015 W. 53RD NORTH  
WICHITA, KS 67204

**838-8497**

NADINE BRUNER  
CEO

ALAN BRUNER  
PRESIDENT

## **EUROPEAN CAR COMPANY**

David Leivian and his European Car Company is located: 122 N. Walnut, Seneca & Douglas.  
**316-734-0985** [eurocarcolic@cox.net](mailto:eurocarcolic@cox.net)

David has a full complement of unique tools. He also maintains high-security storage for the classic, rare, exotic, and collectable, vehicles. Investing in TLC for your beauty now will return many extra years of driving adventures.

**Drop In & See What's Up.**



**CARS and COFFEE - 3RD SATURDAYS MAR - OCT**

**FOR SALE**



**FOR SALE** Chrome Bumper Brown 1972 MGB, WITH Tan Interior, comes with an extra transmission - \$4,600

**ALSO: FOR SALE** Red 1973 Austin Healy (Bottom Right) No title. Xtra Tran \$600. GREAT candidate for a rebuilder!

Contact Rick Rager 619-9203 [rick.rager@yahoo.com](mailto:rick.rager@yahoo.com)



**HEARTBREAK BEAUTY..... STILL FOR SALE:**  
**MAGNIFICENT 1954 Pontiac Star Chief - 2-Tone Green.**  
**Must sell to gain space in garage to restore my aging MGB!**  
**Contact Dan Weaver [dweaver6113@yahoo.com](mailto:dweaver6113@yahoo.com)**

*You may remember Dan Weaver  
as The Counter Man at Kirk's  
Import in the Delano District of  
Wichita during the 1999 - 2005s?*

*He now has to sacrifice the  
above Star Chief Pontiac to  
restore the hungry MGB at right.*

*This **Queen Mary of the 50's** will  
let you create memories that  
only this dying breed can.*



# SEPT - OCT

## KANSAS STATE FAIR

SEPT 6 PUMPKIN WEIGH-IN

SEPT 8 TO 17 7:30 and on

11:00 Woodcarving Demo

2:00 Draft Horses

2:30 Family Theatre

3:00 Homemade Ice Cream Judge

SEPT 9 8:00 Beef, Goat, Swine

9:00 Art Drawing, Llama, Pigeons

11:00 Magic & Ventriloquist Show

(You get the idea.....)

<https://www.kansasstatefair.com/events>

## PATRIOT DAY SHOW

### Honoring Our Heroes

SEPT 10 9 to 1 PM

\$25 Registration 9 to noon

Awards at 1 PM

DONATE A TOY and get \$5 OFF  
The Register Fee!

All toys donated go to the  
2023 Wichita Toy Run

All Wheels Welcome

R. Dole Medical Center  
5500 E Kellogg Avenue

## KINGMAN COUNTY HISTORICAL MUSEUM

### ALL WHEELS SHOW

SATURDAY, SEPT 23

8:30 AM TO 2 pm

FIRST 50 REGISTERED GET  
A DASH PLAQUE

Fee \$15 per vehicle

Prizes awarded at 1:15PM

50 / 50 Money Pot 8:30 - 12:45

Award 50/50 at 1 PM

Questions 620-314-5006

## HILLSBORO ARTS AND CRAFT FAIR

One of a kind creations!

SEPT 16 9 TO 4 PM

LOCAL FOOD, FAMILY FUN,  
VENDORS, CREATIVE ART  
MARKET, SMOKED SAUSAGE,  
ZWIEBACK & BIEROCKS, KETTLE  
CORN, ROASTED ALMONDS, AND  
FUNNEL CAKES!

110 No, Main Street, Hillsboro Ks

## RAIN OR SHINE!